

FALCON CONTINUOUS (C) CONCENTRATORS

APPLICATIONS

- Primary concentration of tin, tantalum, tungsten, chrome, cobalt, iron, fine oxidized coal and uranium
- Scavenging of fine particles lost by low G force processes and flotation
- Pre-concentration of heavy minerals

KEY ADVANTAGES

- Unit capacities up to 100 t/h
- The variable frequency drive (VFD) enables control over G force based on application
- Advanced wear materials and a modular design decreases downtime and reduces maintenance costs.
- High gravitational field (up to 300 G) allows recovery of very fine particles
- No fluidizing water consumption or offline time for concentrate flushing
- Produces high density (variable mass yield 0 – 40%) concentrate therefore no thickeners required
- Continuous production of concentrate at >70% solids
- Greater than 95% mechanical availability, extremely low operating costs
- Small footprint
- Fully automated, "one touch" operation that provides the least amount of offline time and highest possible concentrate security

RECOVERY DOWN TO 10 MICRONS AND UNIT CAPACITIES UP TO 100 t/h

Falcon C Concentrators are typically used in gravity recovery applications that require a higher mass yield to concentrate when compared with SB Concentrators. Often utilized for the recovery of valuable fine particles, Falcon C Concentrators are capable of collecting fines missed by dense medium separators, spirals or any other low G processes.

Designed for continuous duty, these machines are able to produce mass yields as high as 40%. The primary objective of the Falcon 'C's is to maximize recovery and reduce tonnage to downstream processes. The technology is ideal for scavenging or pre-concentrating applications as well since no water is added during processing.

Reliable test work can lead you to the right concentrator for your application. Seapro operates laboratory facilities, which generate decisive data for scale up to commercial operation.



FALCON CONTINUOUS (C) CONCENTRATORS

SPECIFICATIONS

MODEL		C400	C1000	C2000	C4000**	
RECOMMENDED SOLIDS CAPACITY*	t/h	1 - 5	5 - 27	20 - 60	45 - 100	
MAX SLURRY CAPACITY	m ³ /hr	17	74	210	400	
MAXIMUM FEED PARTICLE SIZE*	mm	1.0	1.0	1.0	1.0	
MINIMUM EFFECTIVE CAPTURE SIZE	µm	10	10	10	10	
CONCENTRATE PERCENT SOLIDS	%	65 - 72	65 - 72	65 - 72	65 - 72	
MAXIMUM FEED PERCENT SOLIDS*	%	40 - 45	40 - 45	40 - 45	40 - 45	
CONCENTRATE SURFACE AREA	m ²	0.25	0.60	1.42	2.64	
G-FORCE RANGE	upper	300	300	300	300	
	lower	50	50	50	50	
MOTOR POWER	kW (HP)	7.5 (10)	15 (20)	30 (40)	75 (100)	
PROCESS WATER CONSUMPTION	m ³ /hr	NONE REQUIRED				
MACHINE WEIGHT	kg	1215	2 525	4 615	10 150	
DIMENSIONS	WIDTH	m	1.22	1.55	1.85	2.36
	LENGTH	m	1.22	1.55	1.85	2.36
	HEIGHT	m	1.33	2.18	2.67	2.63

*Denotes application specific parameter, consult manufacturer.

**Special applications only, consult manufacturer.

Note: Specifications are subject to change without notice. Equipment may not operate or achieve best performance under maximum capacities.

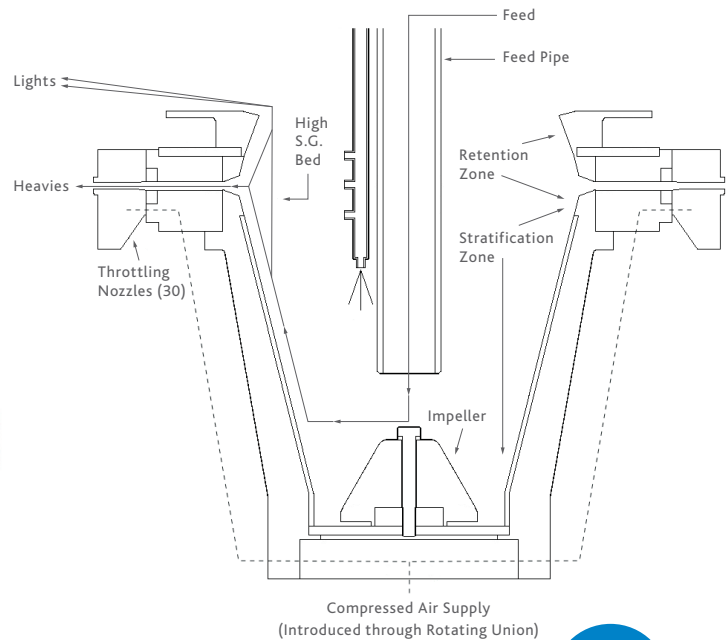
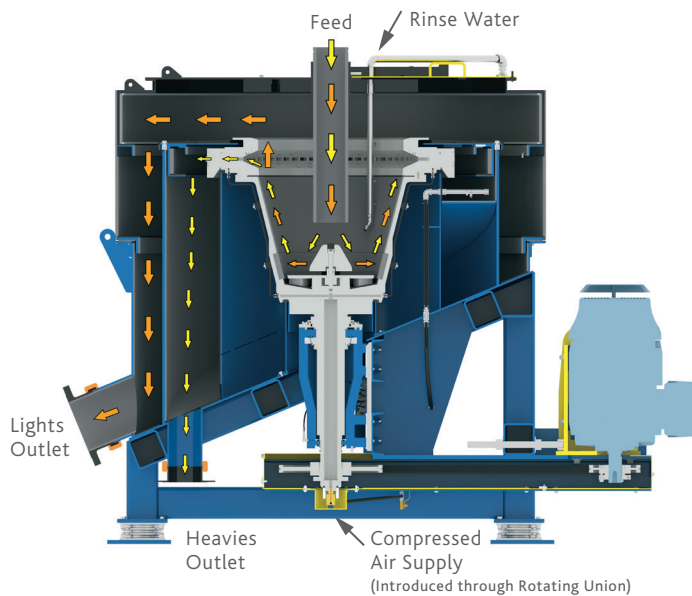

Sepro Mineral Systems Corp.

9850 201 Street, Langley, British Columbia, Canada V1M 4A3

Office: +[1] 604.888.5568 • Fax: +[1] 604.888.5521 • Toll free: +[1] 800.990.5568 North America

sepro@seprosystems.com • www.seprosystems.com

